

USE AND MAINTENANCE MANUAL

BRUSH MOWER TYPE BM / SC - 2008

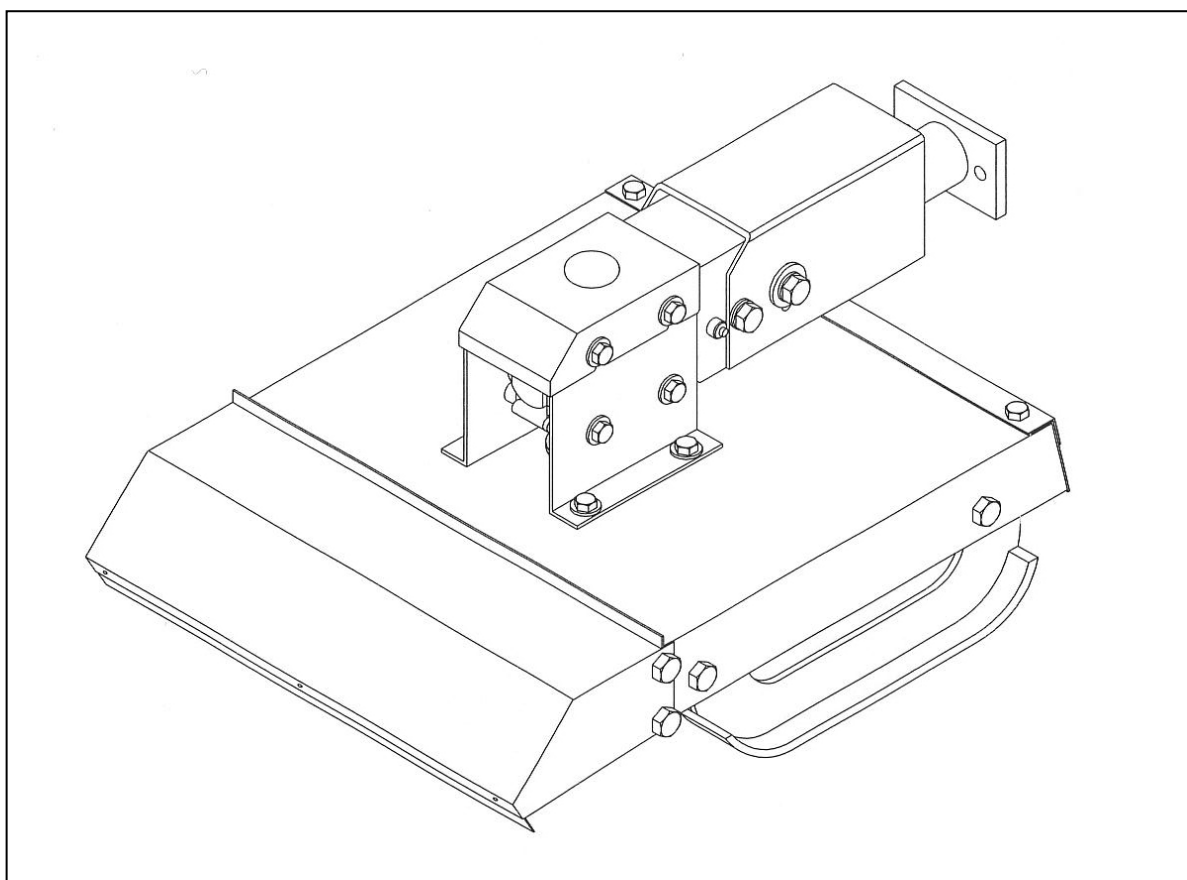

PREFACE

This manual is an integral part of the machine.

It must always accompany the machine and be kept within reach of the operator.
The enclosures mentioned are an integral part of this manual.

The purpose of this manual.

This manual gives information for the correct and safe use of the machine.
The owner must read this manual carefully before work with the machine.

Responsibility of the owner

The owner is responsible for accidents or damages caused to people or things due to negligence in following the instructions in this manual.

Assistance in using this manual

Explanations: contact the dealer.

Request for additional copies of the manual: in case of loss or wear and tear, or in case one wants the manual in a different language, the customer should ask the dealer or manufacturer.

Pay attention to the warning signals



<Danger>: indicates a situation that is potentially dangerous which, if not avoided, will cause death or serious damage.



<Warning>: indicates a situation that is potentially dangerous which, if not avoided, will cause death or serious damage.



<Caution>: indicates a situation that is potentially dangerous which, if not avoided, can cause minor to moderate damage, or it indicates to be careful about an unsafe procedure.

<Important>: indicates instructions that must be followed precisely in order to avoid damage to the product, process

or environment.

<Note>: indicates supplementary information.

DESCRIPTION

FUNCTION OF USE

This machine, thanks to its versatility, accomplishes both the function of mower and brush mower. The quickly and easy application of various device types, permit to obtain a good finishing in grass cutting (with fixed blade) and a radical scrub clearing (with jointed blade).

PERFORMANCES

The machine is connected with the walking tractor with a joint that besides to transmit the power allows a rotation of the machine around its longitudinal axis that aids adaptability with any ground.

The connection group can rotate about 20° as to transversal machine axis, so it's possible the connection with any walking tractor.

The cutting height is adjustable in three pre-determined positions from 2,4 to 4,15 inches.

PERFORMANCES LIMIT

- ❑ Maximum forwarding speed: 3 m.p.h.
- ❑ Speeds greater than the maximum can compromise the condition of the machine, the quality of the work and the safety of the operator.
- ❑ Maximum power applicable to the gear box: from 6 to 8,7 Kw \pm 5% according to the type.
- ❑ Superior power to which is indicated can damage irreparably the transmission gear box; especially during heavy works.

STANDARD EQUIPMENT

- **Flat jointed blade**

TECHNICAL SPECIFICATION

CHARACTERISTICS PER MODEL

Model	Type	Power		PTO g/min	Cutting width		Cutting height		Blades N°	Blades speed r.p.m.	Weight	
		Hp	Kw		cm	Inch	cm	Inch			kg	Lbs
BM	21 BCS	13	8,7	800	53	21	6÷10.5	2.4÷4.15	2	2400	43	95
	21 GRI	13	8,7	800	53	21	6÷10.5	2.4÷4.15	2	2400	43	95
	26 BCS	13	8,7	800	67	26	6÷10.5	2.4÷4.15	2	2400	53	117
	26 GRI	13	8,7	800	67	26	6÷10.5	2.4÷4.15	2	2400	53	117
	31 BCS	13	8,7	800	81	31	6÷10.5	2.4÷4.15	2	2400	63	139
SC	53	13	8.7	800	53	21	6÷10.5	2.4÷4.15	2	2400	43	95
	67	13	8.7	800	67	26	6÷10.5	2.4÷4.15	2	2400	53	117

Note:

- The machines type BM21BCS, BM26BCS, BM31BCS are with attachment BCS.
- The machine type BM21GRI, BM26GRI is with attachment GRILLO.
- The machines type SC53 are with attachment Bertolini 401/402 or Bertolini 406/408 or Adriatica.
- The machine type SC67 is with attachment Bertolini 406/408.

SAFETY INFORMATION

GENERAL REGULATIONS

- ❑ Only work in daylight.
- ❑ To prevent damage due to lurch of objects or parts of blades, before to start job be sure that any persons or animals should be in the radius of 50 meters from the machine.
- ❑ Wear long pants and heavy shoes.
- ❑ The protections are integral part of the machine: always work with the protections.
- ❑ Pay attention to the soil: make sure that are not stones, sticks, iron wires, etc...
- ❑ Pay attention using the machine on slopes: proceed to the maximum slope and never work in slanting direction.
- ❑ Before leaving the driver's seat, turn off the engine and disengage the transmission engine-shaft.
- ❑ Check immediately the machine if it touches foreign objects.
- ❑ Check immediately the machine if there are unusual strong vibrations.
- ❑ Change quickly defective parts.

SAFETY RESTRICTIONS

Children and people who are not familiar with these instructions must not be permitted to use the machine. Local regulations can restrict the use of the machine in accordance to the age.

SAFETY SIGNS ON THE MACHINE

In this section the safety signs on the machine are reproduced and explained.

WARNING

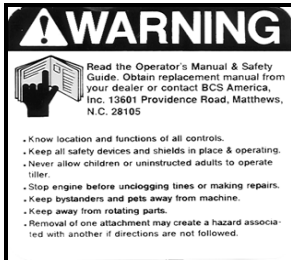

1

DANGER

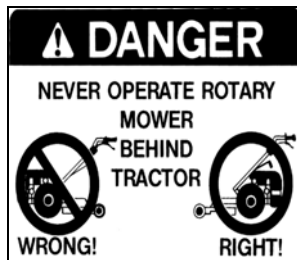

2

DANGER



3

1. Read the operator manual.
2. Danger.
3. Danger, stay at safety distance from blades until machine moves.

The safety signs on the machine must always be legible.

In case of damage, the labels of the signs must be substituted.

In the case of the substitution of machine parts that have safety signs, the signs must be replaced.

Supplying of new safety labels and the application procedure

Contact your dealer to receive new safety labels with instructions for application.

INSTRUCTIONS FOR USE

BEFORE BEGINNING WORK

a) Adjust front baffle opening as follows:

1. Unscrew and take out the two screws "L" and unscrew the two screws "I" on two machine sides.
2. Adjust position of baffle "H".
3. Plug in and lock screws "L", lock the screws "I".

b) Adjust cutting height operating as follows :

1. Unscrew and take out the screws "D" on machine right side.
2. Adjust cutting height moving slide "C" towards up to decrease and towards down to increase.
3. Plug in and lock screws "D".
4. Repeat the same operations on the other machine side make sure to set up the same cutting height on the two slides.

c) Hook the machine to the walking tractor operating as follows :

1. Put the machine and the walking tractor on a flat ground and loosen screws "E" and "F".
2. Lean all slides "C" flat side on the ground.
3. Approach the machine to the walking tractor, insert screws in the holes of flange "G" and lock with washers and nuts.
4. Lock screws "E" and "F".
5. Check oil level in the gear box removing cap "A" and unscrew plug "B" (see point "2-a page 10).

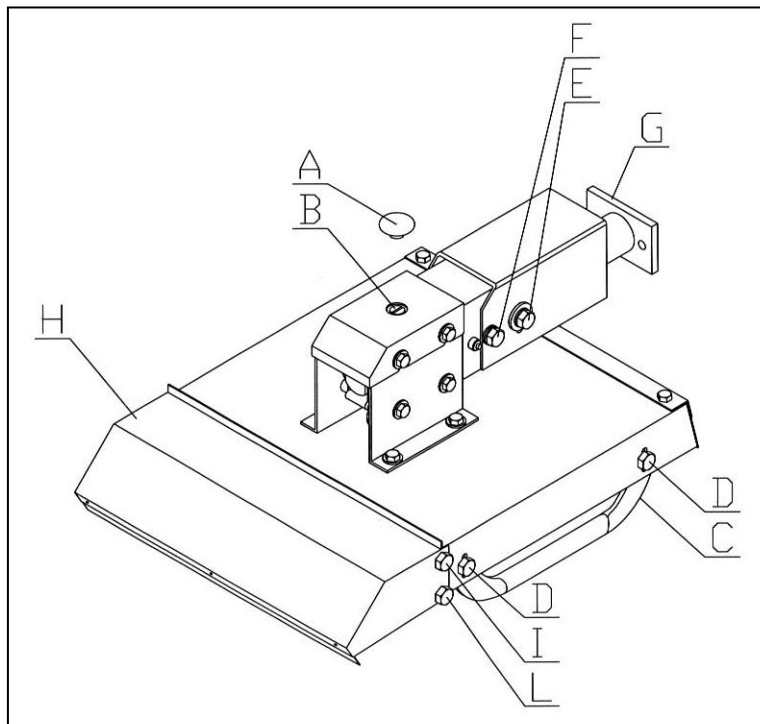

TO BEGINNING WORK

- a) Keep people and animals at least 65 feet radius all around the machine.
- b) Raise the machine from ground.
- c) Connect PTO power and gradually bring it to good speed.
- d) Pull down slowly the machine and start the work.

AT THE END OF WORK

- a) Stop the walking tractor.
- b) Disconnect PTO power.
- c) Raise the machine and clean its lower side.

MAINTENANCE INSTRUCTION

On schedule "A" the maintenances are indicated with their terms to effect on the machine.
 Not follow the scheduled terms can compromise the functionality of the machine and in this case the warranty is not applicable.

SCHEDULA "A" - SCHEDULED MAINTENANCE

	FIRST START	AFTER 10 HOURS	EACH 30 HOURS	EACH 500 HOURS	END SEASON	BEGIN. WORK	END WORK
MACHINE					Cleaning		Cleaning
GEAR BOX		Level	Level	Change oil			
HUB	Greasing	Greasing					
SCREW		Locking	Locking				
BLADE			Check Sharpness Balance				Check Cleaning
FRONT RUBBER PROTECTION						Check	
REAR RUBBER PROTECTION						Check	

1. GREASING

The only greasing point is equipped with greaser HYDRAULIC TYPE MODEL "A" UNI 7663.
To grease use only MULTIFUNCTIONAL GREASE LITHIUM BASED Type NLGI 2.
The only greasing point is the point "C" located on one side of the hub.
Greasing operation must be made at the terms scheduled on schedule "A".

2. OIL LEVEL - OIL SUBSTITUTION

At scheduled time on schedule "A", change oil in gear box.
Use only OIL SAE 90 EP.
Gear box capacity: 0,350 l

a) To check oil level in gear box, operate as follows :

1. Unscrew plug "B" after removing cap "A".
2. With the machine straight and on level check oil level.
3. If necessary fill oil.
4. Screw plug "B" and put in position cap "A".

b) To check oil level in gear box, operate as follows :

1. Unscrew plug "B" after removing cap "A".
2. Turn upside down the machine and drain oil in a suitable tank.
3. Put the machine straight and on level, put oil through hole "B".
4. At the end of fill screw plug "B" and put in position cap "A".

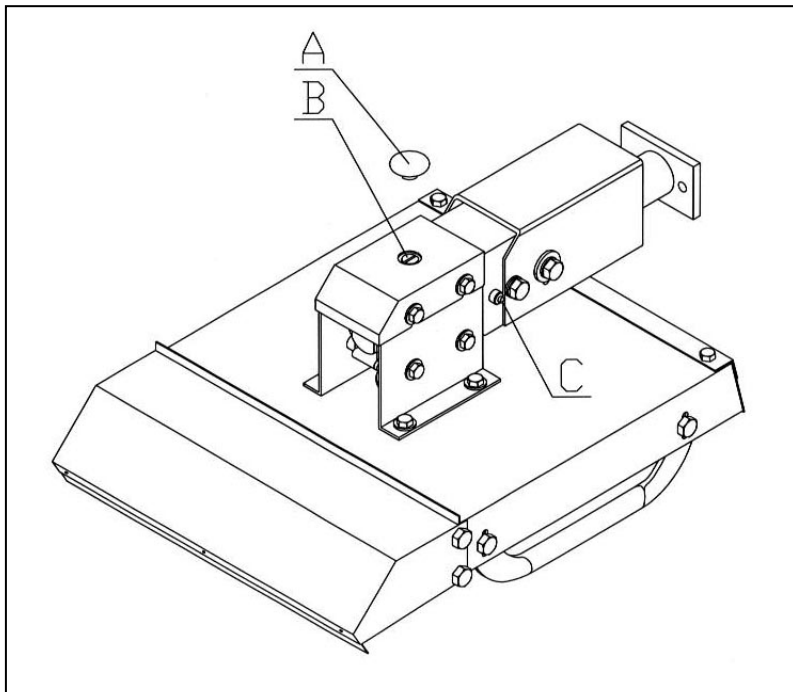

3. BLADE SUBSTITUTION

a) To change blade, operate as follows:

1. Unscrew nut "A" and take off pin "D" with respective spacer "B" from blade "C".
2. Plug in pin "D" in new blade putting pin head in the suitable slot, insert the spacer "B".
3. Plug in pin in the blade case and lock nut "A".

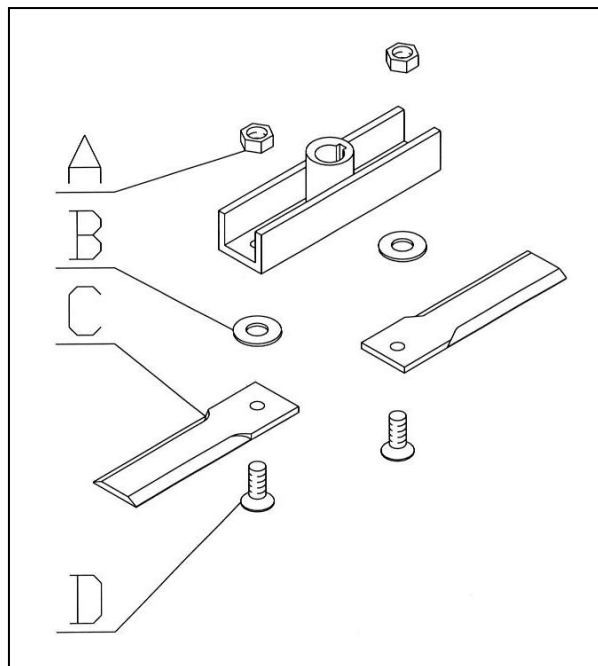

PROBLEMS SOLVING

TROUBLES	CAUSES AND SOLUTIONS
Abnormal vibrations	-Damaged blade - Replace -Broken blade - Replace -Not balanced blade - Balance
Uneven or unsatisfactory cut	-Not sharp blade - Sharp

TRANSPORT

Except when working, moving the machine takes place when the machine is standing still and the transmission is disconnected.

<Important>: keep speed low avoiding holes and ground roughness.

<Important>: Before begin the movements always make sure that the safety hooks be in position.

<Note when on the road, obey existing traffic laws. Exhibit the signal signs on the rear ends. Respect any local laws there may be.

STORAGE

Store the machine in a dry place that isn't dusty.

INFORMATION ON DEMOLITION



At the end of its working life, the machine must be sent to be demolished and that can only be done by an authorized authority, in accordance with the national laws in force for the environment. Therefore it is necessary to get information from the qualified local authorities on the procedure to follow. The machine is mainly composed of: iron materials and paints.

WARRANTY

The machine is covered by the manufacturer warranty for a period of 24 months.

The warranty is not applicable when:

- a) The maintenance work has not been done correctly.
- b) The machine has been used out of its own service.
- c) The machine has been transformed or modified without the manufacturer's written authorization.

WORK AND MAINTENANCE SHEET

Every user should register on this sheet the facts about the life of the machine (both work and maintenance), so as to attest its conditions.

DATE	WORKING HOURS	MAITENANCE	NOTE	USER

YOUR OBSERVATION FOR IMPROVEMENTS

Customers can record on this sheet any observations on the performance of the machine, including possible problems.

Observations coming directly from the work field are of great help in improving the product. We now thank those who will give us this help.

SPARE PARTS ORDERS

If you must order some spare parts, please follow these instructions :

- ❖ Take the spare parts list and the spare parts drawing enclosed in this manual.
- ❖ Identify the spare parts to order with respective code and quantity and make a list of them
- ❖ Find the identification table, showed below, placed on the top of the deck and write on the list the "MODEL", "SERIAL NUMBER" and "YEAR OF PRODUCTION" of your machine .
- ❖ Send the list to your dealer.

	Made in Italy by DELMorino S.R.L. Farm & Garden Equipment. 52033 - CAPRESE MICHELANGELO (AR) - ITALY		
MODEL	<input type="text" value="BM 21"/>	RELEASE	<input type="text"/>
CONFIGURATION	<input type="text"/>	CUSTOMIZED	<input type="text" value="B.C.S."/>
SERIAL N°	<input type="text" value="527"/>	YEAR	<input type="text" value="1999"/>

SPARE PARTS

BM21 – BM26 – BM31 / 2008 BCS SPARE PARTS

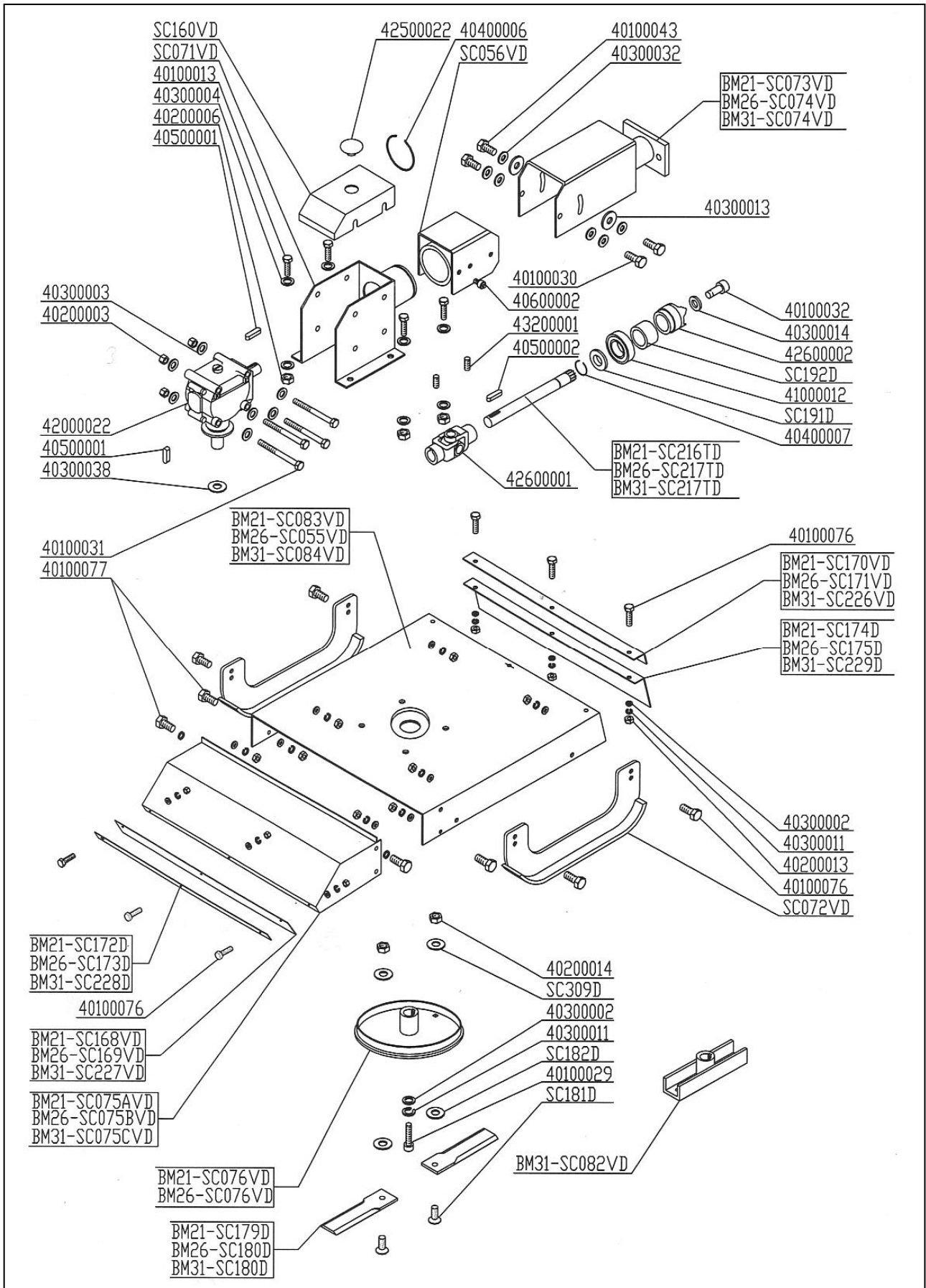

BM21 – BM26 GRILLO / 2008 GRILLO SPARE PARTS

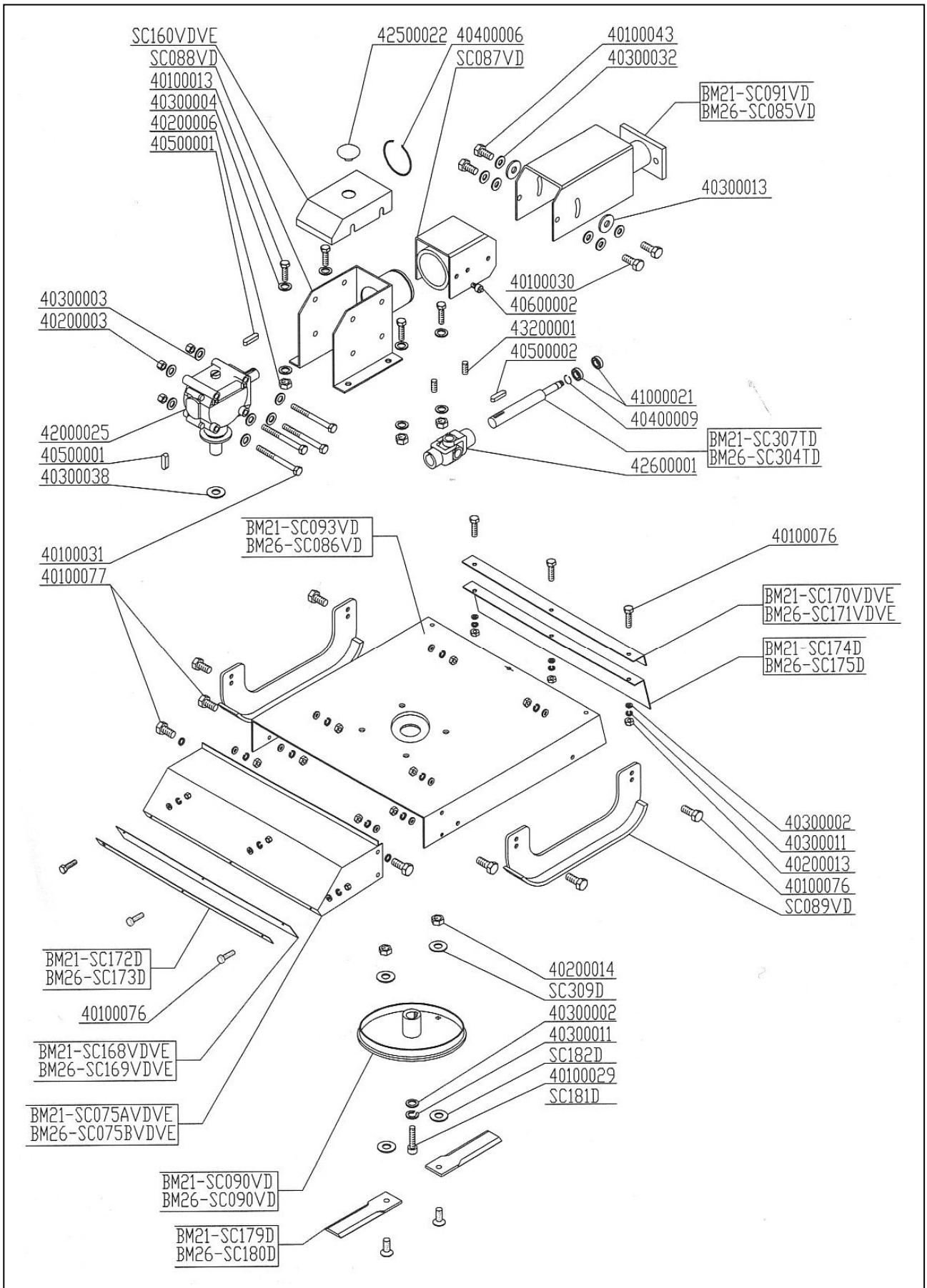

SC53 – SC67 / 2008 SPARE PARTS

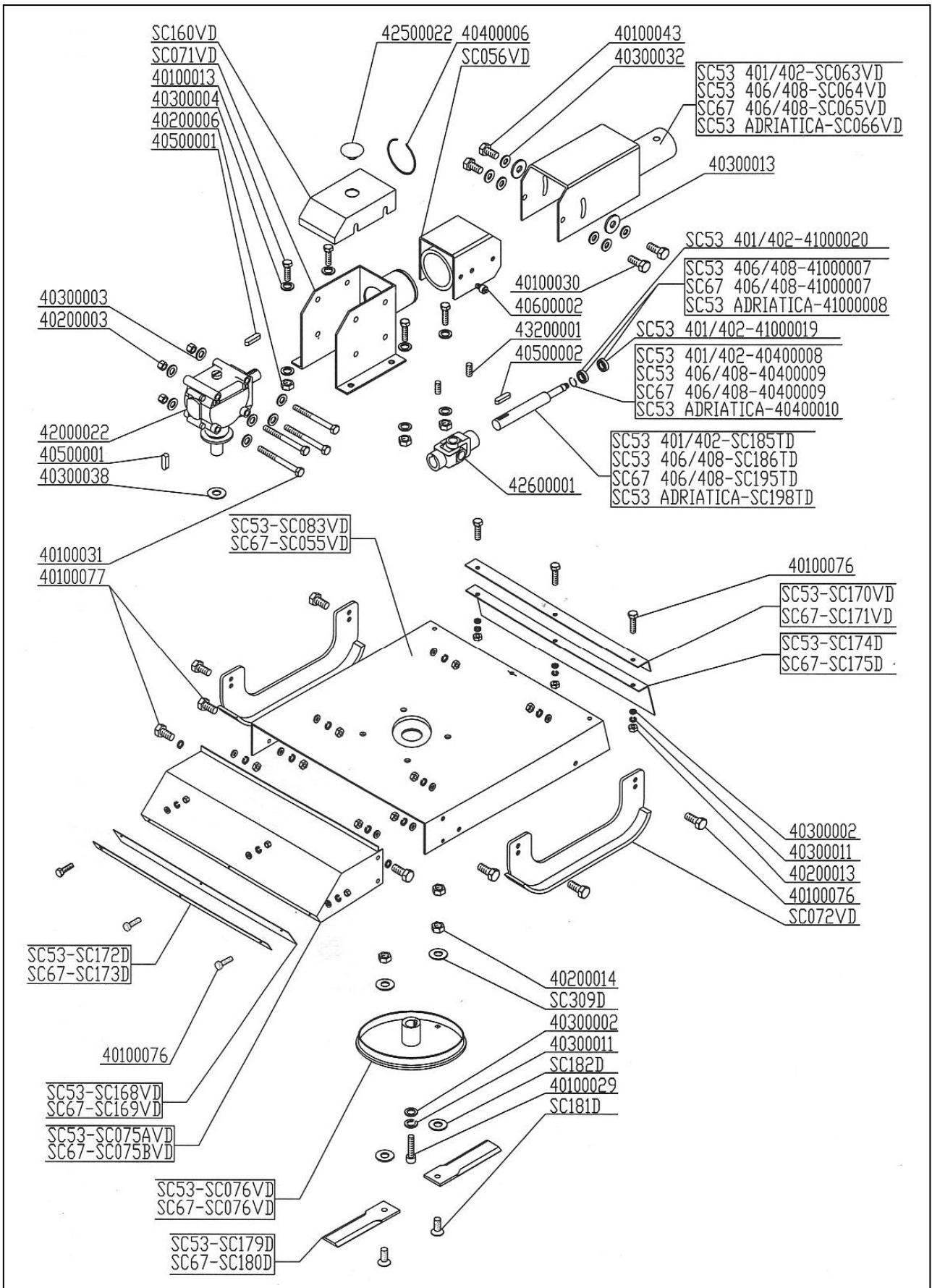

TABLE OF CONTENTS

PREFACE	2
DESCRIPTION	3
PERFORMANCES	3
PERFORMANCES LIMIT	3
STANDARD EQUIPMENT	3
TECHNICAL SPECIFICATION	4
SAFETY INFORMATION	5
GENERAL REGULATIONS	5
SAFETY RESTRICTIONS	5
SAFETY SIGNS ON THE MACHINE	6
INSTRUCTIONS FOR USE	7
BEFORE BEGINNING WORK	7
TO BEGINNING WORK	8
AT THE END OF WORK	8
MAINTENANCE INSTRUCTION	9
SCHEDULA "A" - SCHEDULED MAINTENANCE	9
1. GREASING	10
2. OIL LEVEL - OIL SUBSTITUTION	10
3. BLADE SUBSTITUTION	11
PROBLEMS SOLVING	12
TRANSPORT	13
STORAGE	13
INFORMATION ON DEMOLITION	13
WARRANTY	13
WORK AND MAINTENANCE SHEET	14
YOUR OBSERVATION FOR IMPROVEMENTS	15
SPARE PARTS ORDERS	15
BM21 – BM26 – BM31 / 2008 BCS SPARE PARTS	17
BM21 – BM26 GRILLO / 2008 GRILLO SPARE PARTS	18
SC53 – SC67 / 2008 SPARE PARTS	19